

## **An Innovative Solution for the Repair of the Sepulveda Feeder**

By: Michael McReynolds P.E.<sup>1</sup>

### Abstract

In January 1998, a routine inspection of the Sepulveda Feeder revealed that the 3.81 meter (150") diameter prestressed concrete cylinder pipe (PCCP) was damaged near one of the joints. The damage, which was most likely caused by the 1994 Northridge Earthquake, consisted of a ruptured steel cylinder and cracked mortar covering the prestressing wire. The damaged pipe section was under about 9 meters (30') of cover, adjacent to an encasement and located close to a large flood control conduit in an area with high ground water.

Normally, Metropolitan would either replace the damaged section or repair the damage with an external steel sleeve. In this case neither option was possible. The area below springline had been backfilled with concrete, making it almost impossible to excavate below the springline. There were also access problems caused by a nearby storm drain. Therefore, another solution was required.

The final repair involved cutting off and removing the top of the prestressed pipe, sliding a series of steel cylinders into the damaged section, and then welding the new cylinders to the existing spigots. The annular space between the PCCP and the cylinders was filled with grout, and then a concrete slab was placed over the pipe to carry the cover. This solution restored the pipe's initial integrity without adversely affecting adjacent structures.

---

<sup>1</sup> Engineer, Metropolitan Water District, 700 North Alameda Street, Los Angeles, California 90012

## The Pipeline

The Metropolitan Water District is the major water wholesaler for southern California. The Sepulveda Feeder is a 3.81 meter (150") diameter prestressed concrete cylinder pipe (PCCP) which carries finished water from Metropolitan's Jensen Filtration Plant to member agencies on the west side of Los Angeles county.

## Finding the Problem

The Metropolitan Water District internally inspects its PCCP pipelines every five years. In January 1998, a routine inspection found water coming into the Sepulveda Feeder at Sta. 150+74, roughly 2.4 kilometers (1.5 miles) from the water treatment plant. At this location, the pipeline descends down a steep slope (34%) and turns at a vertical PI at Sta. 150+55. The pipeline is also encased at this location to carry the load of 9 meters (30') of cover.

The damaged section was at a joint about 0.6 meters (2') from the end of an encasement. The Sepulveda Feeder was most likely damaged by a compression wave from the Northridge Earthquake. The compression wave probably slammed the pipe into the encasement. The concrete core and mortar coating were cracked and the embedded steel cylinder buckled due to the compressive forces in the pipeline.

After inspecting the damage, it was determined that the pipe was still structurally sound but should be repaired as soon as possible. As a temporary repair, an internal steel band was placed inside of the pipeline to prevent water from entering and exiting the pipeline through the damaged joint.

## Potential Repair Methods

To get a better idea of the extent and severity of the damage, Metropolitan planned to excavate and inspect the exterior of the Sepulveda Feeder. This inspection would also enable Metropolitan to determine the best method of repairing the damage.

Conducting an external inspection, however, proved to be difficult for the following reasons:

- The pipeline had about 9 meters (30') of cover.
- The damaged section was in a creek bed, making it very susceptible to flooding during the rainy season.
- The size of the excavation site was severely restricted by storm drains to the east, west, and south and by a steep slope to the north.

- The groundwater table was also 1.5 to 2.0 meters (5 to 7 feet) above the crown of the pipe. Dewatering wells were installed but were unsuccessful in lowering the groundwater table.

Metropolitan originally intended to either replace the damaged section entirely or to repair the pipe by placing an external band around the damaged portion of the pipe. Repairing the pipeline with an external band was the preferred alternative, because of its lower cost and limited shutdown time. The band would be designed to carry the internal pressure and would have the added benefit of protecting the pipe from further corrosion.

The work began in October 1998. First, the top of the pipe was exposed (by means of an open cut excavation) and inspected. The mortar coating on the pipe segment adjacent to the encasement was cracked. An excavation to expose the invert of the pipe was started so that the repair band could be installed. However, the soldier piles could only be driven to approximately the spring line of the pipeline. The reason was that the site had been washed out during the original construction of the Sepulveda Feeder and the washed out trench backfill had been replaced with concrete slurry. This meant that the two methods proposed for repairing the pipe (i.e. the steel band or pipe replacement) were not feasible.

#### Other Methods Explored

Since the physical characteristics of the site did not permit repair of the Sepulveda Feeder by either replacing the pipe or wrapping it with a steel band, other alternatives were explored.

One potential solution involved dropping 3.65 meter (144") diameter steel cylinders down an open-air shaft about 2.4 kilometers (1.5 miles) upstream from the location of the repair. The cylinders would be transported inside the Sepulveda Feeder to the repair location. The Sepulveda Feeder slopes gently downhill for the majority of this distance but has a 34% slope for the last 30 meters (100'). This option was ruled out because moving the steel cylinders 2.4 kilometers (1.5 miles) inside the pipe would be too difficult and posed serious safety hazards.

Another alternative was to use fiberglass reinforcement inside of the pipe. This alternative was rejected for two reasons. First, the presence of ground water would have made the installation of the fiberglass reinforcement difficult. Second, there was no guarantee that ground water would not seep between the fiberglass liner and the PCCP during shutdowns creating a cross connection.

#### The Repair Method

After evaluating several alternatives, Metropolitan selected a repair method that was both innovative and effective. The method consisted of excavating the pipe to the springline, cutting off the top half of the PCCP pipe, and dropping a series of steel cylinders into the pipe through the newly cut hole. The cylinders would then be welded into place. This method had several benefits over the other alternatives, with the primary benefit being a guaranteed repair: Because the damage was at an encased pipe joint, there was no way of determining if only one or both of the pipe sections were damaged. This alternative insured that both pipe sections would be structurally sound.

The repair procedure follows:

1. First, the shoring was redesigned. Metropolitan had planned to use steel lagging and braced soldier piles for shoring, but since the pipe was only going to be excavated to the springline, the shoring was modified to act like a shield instead of a braced soldier pile.
2. Next, the location of the hole to be cut in the top of the pipe was marked and the mortar coating over the prestressing wires was removed at springline on both sides of the pipe. The prestressing wires were then cut.

There was some concern about cutting the prestressed wires for safety reasons. It was feared that they might spring loose and hurt someone. In fact, cutting the wires with a torch was very effective because the wires would stretch as the heat from the torch was applied and then break. The only dangerous situation occurred when the mortar coating began coming off as more prestressed wires were cut. At that point, the cutting of the wires was stopped and the rest of the mortar coating was removed. Then the remaining prestressed wires were cut. After all of the prestressed wires were cut, they were bundled together and removed.

3. Next, a 3.0 meter (9'-8") long section of the top half of the pipe was cut off. The vertical cuts were made with a wire rope saw blade that was strung through holes drilled into the pipe at springline. A large concrete circular saw was used to make the horizontal cut. The top of the pipe was then removed.
4. The next phase of the repair was to chip out the mortar lining at the joint locations where circular steel plates, called grout dams, were to be welded into place. A chipping gun and a rivet buster were used to remove the mortar lining. The chipping gun was successful in removing the mortar lining but the progress was slow relative to the rivet buster. The rivet buster effectively removed the mortar lining but it also punched a hole through the spigot on the downstream side of the repair. It also made deep gouges in the existing bell and damaged the o-ring.

5. After the mortar lining was removed, the grout dams were lowered into the PCCP through the newly-cut hole. The grout dams were welded to the existing spigots 17 cm (6.75") from the end of the spigot to ensure that the heat from welding would not damage the existing "O" rings (see Figure 1). It was important not to damage the "O" rings because they ensured that the pipe would remain watertight. As previously mentioned, one of the "O" rings was damaged during the removal of the mortar lining, so the existing spigot was welded to the existing bell in order to prevent leaks. The welding of this joint increased the length of the shutdown by 5 hours.
6. After the grout dams were welded into place, the steel cylinders were lowered into the PCCP and moved into position. This was a very tricky phase of the project. The length of the hole, position of the hole, and the length of the steel cylinders dictated that the steel cylinders could only be placed into position one at a time and only in a specific sequence. If the cylinders were not placed in the correct sequence and positioned properly, subsequent cylinders could not be lowered into the pipe.

Another problem was moving the steel cylinders into position once they had been lowered into the pipeline. It was planned to use a small cart to move the steel cylinders after they were lowered into the pipe. But moving the cylinders into position proved to be more difficult than originally anticipated because the pipe was so large. A 3.65 meter (12') diameter pipe is not only heavy but awkward to handle. The problem was solved by welding lugs to the first steel pipe section just upstream of the repair and dragging the cylinder into position using winches. Once the cylinder was in position it was blocked and welded to the dam.

The next two steel cylinders were put into position using the cart to support one end of the cylinder and the crane to support the other end. The second cylinder was inserted into the bell on the first cylinder and welded into position. The third cylinder was then moved into position, blocked and welded to the grout dam on the downstream end of the repair. The fourth cylinder was then lowered into position and welded to the adjacent cylinders by means of buttstraps. The buttstraps were welded onto the bottom of second and third cylinders and onto the top of the fourth cylinder. See Figure 3.

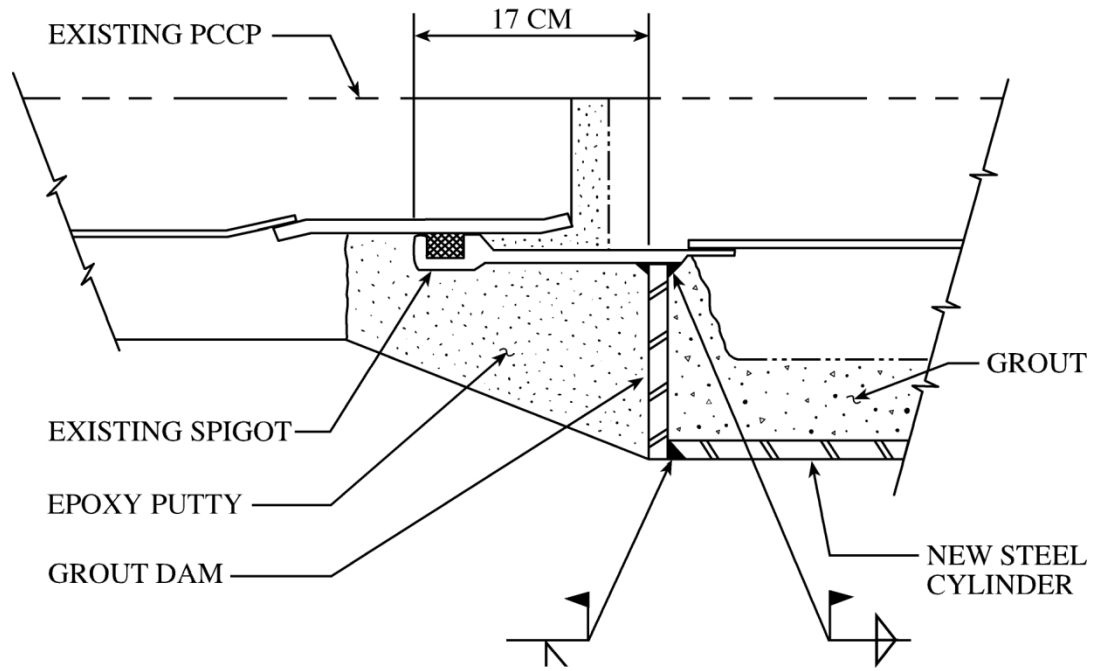

GROUT DAM WELDED TO EXISTING SPIGOT - FIGURE 1

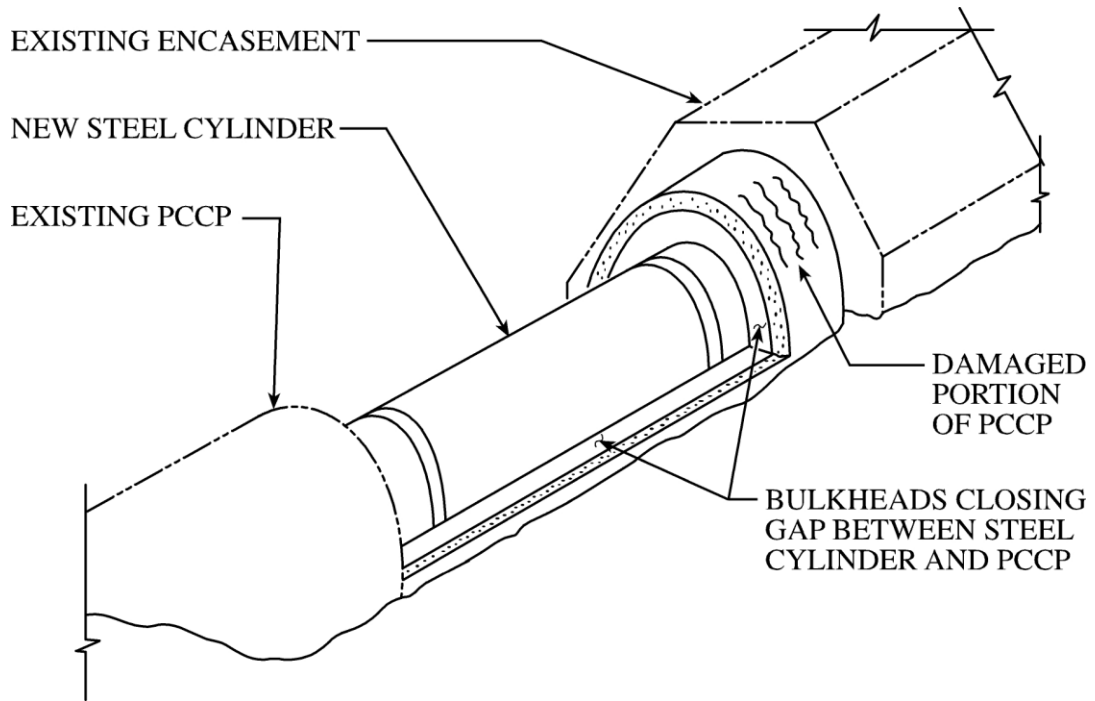

BULKHEAD FOR GROUTING GAP BETWEEN CYLINDER AND PCCP  
FIGURE 2

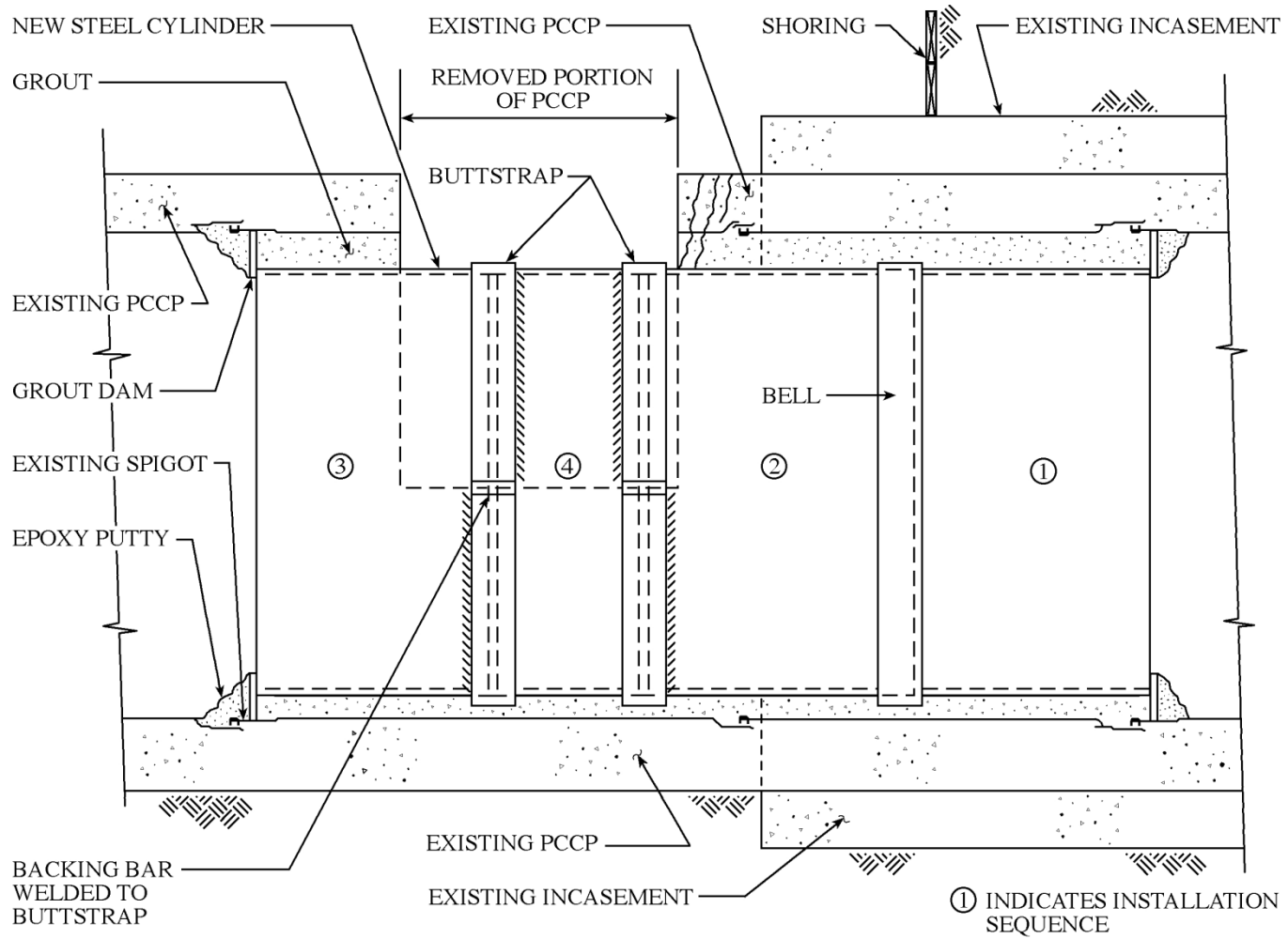

**DETAIL OF INTERNAL STEEL CYLINDERS - FIGURE 3**

The next phase of the repair consisted of welding steel plates between the existing pipe and the new cylinders (See Figure 2). This was done to close the annular space between the existing concrete pipe and the new steel cylinders so they could be filled with grout. The annular space between the concrete pipe and new steel cylinders was then filled with grout through couplings in the new steel cylinders.

During this phase of the construction, grout was pouring out through the cracks in the damaged PCCP. This threatened to make the repair worthless because the annular space between the PCCP and the steel cylinders could not be filled with grout. This problem was solved by sealing the cracks where grout was escaping with rapid set concrete. The rapid set concrete was mixed with hot water so that it would set up in a matter of minutes. The rapid set concrete was pushed into the cracks and was able to hold enough pressure for the grouting to be completed.

8. The inside of the steel cylinders were then sandblasted. The sandblasting removed any damaged epoxy lining (the lining was damaged where the plates used to close the annular space were welded to the new steel lining) and prepared the unlined surfaces of the cylinders. After the sand blasting was completed, the cylinders were given one coat of high solids epoxy. Simultaneously, epoxy putty was used to cover the bell and spigot that had been exposed so the grout dam could be welded in place. During this phase of the repair, the gouge in the existing spigot caused by the rivet buster was discovered. It had completely penetrated the spigot. The spigot was obviously compromised. Consequently, this joint was sealed by welding the joint and a plate was welded over the hole. As soon as the epoxy was cured, the line was put back in service.
9. The final phase of the repair consisted of installing a concrete slab over the pipe to carry the weight of the 9 meters (30') of cover. Then the shoring was removed and the site restored to its initial condition.

### Lessons Learned

There are several lessons that can be learned from this repair:

- The gap between the steel cylinders and the PCCP should be a minimum of 5 cm (2") for pipe less than 180 cm (6') in diameter and at least 10 cm (4") for larger diameter pipe. The reason for this gap size is to prevent the steel cylinders from resting against the PCCP. Large diameter cylinders can deflect significantly and are difficult to center inside the existing pipe. A 10 cm (4") gap will provide adequate

annular space between the steel cylinder and the PCCP to allow proper grouting.

- The size of the hole to be cut in the top of the pipe, the sequence of installing the steel cylinders inside the PCCP and the length of the cylinders are all critical. Ideally, the hole in the top of the PCCP should be as large as possible so that the steel cylinders placed inside the PCCP can be as long as possible. The sequence for placing the cylinders inside the pipe should also be carefully considered. The last two cylinders may need to be smaller than the other cylinders because the length of the hole is reduced by the previously installed cylinders (see Figure 3). If the last two cylinders are too long they will not fit through the hole in the top of the pipe. When considering the length of a cylinder include the buttstraps because they effectively make the cylinders longer. Even the last cylinder to be installed should be checked to insure its buttstrap does not hit the existing PCCP.
- Only chipping guns should be allowed to remove the concrete mortar over the existing bell and spigot. This will insure that the bell and spigot are not damaged by the chipping operation.
- Rapid set concrete should be used in lieu of epoxy putty to cover the exposed bell and spigot. The epoxy putty is very difficult to use and apply and its curing time is too long. Rapid set concrete can be applied much faster and will protect the bell and spigot just as effectively.
- Quality control and inspection are extremely important. This type of repair requires that the cylinders be made to the exact dimensions specified, the cylinders must be round, and the fitup tolerances must be held precisely.

### Conclusion

This repair method was ideal for the repair of the Sepulveda Feeder but should be considered only as a last resort in most other applications, since it is much easier to replace a section of pipe than to perform this repair. However, for those rare circumstances where full excavation of the pipe is impossible, or the pipe damage is inside an encasement, this method of repair should be considered.

Steel lining a damaged PCCP provides a repair that is equal to replacement of the pipe itself. The steel cylinder is designed to take the internal pressure. The PCCP is only a protective sleeve. The steel cylinder can be designed to carry the

external cover or a protective slab can be placed over the cylinder to protect it from high cover loads.

After the mortar coating was removed from the prestressing wires and the top of the pipe was cut off, the amount of damage to the pipe became evident. The integrity of the steel cylinder had been compromised and the prestressing wires were showing obvious signs of corrosion. By repairing this pipe, Metropolitan averted a catastrophic failure. Failure of this pipeline would have been dangerous, extremely costly and would have interrupted water delivery to thousands of people. Even though this method of repair was costly and difficult, it was the best alternative. The Sepulveda Feeder's integrity at this location is now assured.

Key Words

PCCP

Repair

Seismic Repair

Metropolitan

Steel Liner

Chipping Gun

Mortar Lining

Sepulveda Feeder

Northridge Earthquake

Cylinder